

Item No.: _____

Project: _____

Quantity: _____

Deck Ovens - Electric (1, 2, 3 and 4 Pan)

Series SE-900



SE-934 Shown



Meets UL 197 and NSF 4 Standards

Short Bid Specification:

Appliance shall be an **LBC Bakery Equipment Model SE-9XY** (for X, insert 1, 2, 3 or 4 to indicate pan capacity per deck; for Y, insert 1, 2, 3 or 4 to indicate number of decks) electrically heated deck oven. Ovens will hold 18" x 26" sheet pans accordingly and shall have stainless steel exterior construction, full-view tempered glass doors that open up and in, interior lighting, 5/8" glass fiber concrete hearth stone(s), tubular heating elements, independently heated steamer, maximum set point of 550 deg F, proportionally controlled and independent top and bottom heat, 99 minute timer and a buzzer to indicate preheat and timer have elapsed, plus all the features listed.

Standard Product Warranty:

One Year Parts and Labor (Contiguous US, Alaska, Hawaii & Canada)

Maximum Capacities per Oven Model:

Model		18" x 26" Sheet Pans	26" Baguettes	9" Pies
1 Pan Ovens	SE-911	1	5	6
	SE-912	2	10	12
	SE-913	3	15	18
	SE-914	4	20	24
2 Pan Ovens	SE-921	2	10	12
	SE-922	4	20	24
	SE-923	6	30	36
3 Pan Ovens	SE-931	3	15	18
	SE-932	6	30	36
	SE-933	9	45	54
4 Pan Ovens	SE-941	4	20	24
	SE-942	8	40	48
	SE-943	12	60	72
	SE-944	16	80	96

Construction Features:

- Heavy-duty stainless steel exterior
- Removable 5/8" glass fiber concrete hearth stone(s)
- Stackable up to 4 decks
- Swivel casters with leveling feet
- Full-view tempered glass door(s)
- Bright xenon interior lighting

Performance Features:

- 550 deg F temperature maximum
- Robust, individually-controlled steam system with manual damper supplied with every deck
- Complete steamer recovery within 20 min or less
- Tubular elements for rapid heating
- Independently controlled top and bottom heat
- Loading doors open inward for safety and to retain heat and steam

Control Features:

- Intuitive layout
- Large digital displays for set point, actual temp, and time
- Separate controls for each deck
- Top and bottom heat adjustment per deck
- 99 programmable recipes
- Three Quick Select buttons to access most-used recipes
- 99 minute timer
- Temperature displays in deg F or deg C

Deck Ovens - Electric (1, 2, 3 and 4 Pan)

Series SE-900

Installation Requirements:

- Deck ovens ship fully assembled or disassembled in one crate. Decks can be shipped individually upon request (additional charges may apply)
- 208V, 3ph, 60Hz electrical required (standard configuration). Other optional voltage and phase options are also available (see below)
- Multiple or single decks can be field connected to a single power source
- Use copper wire only (90 deg C minimum) for power connection
- Clearance from combustible surfaces: 1", sides and back; 6", top

Options and Accessories:

240V, 3ph, 60hz Electrical

480V, 3ph, 60hz Electrical

240V, 1ph, 60hz Electrical
(1, 2 and 3 pan deck ovens only)

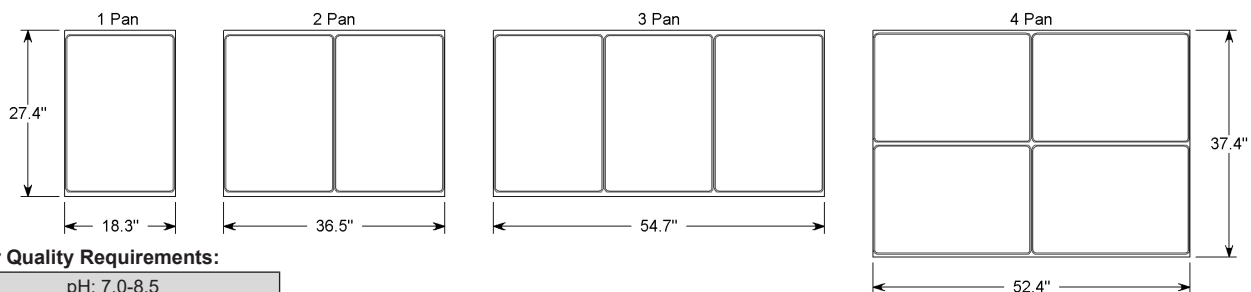
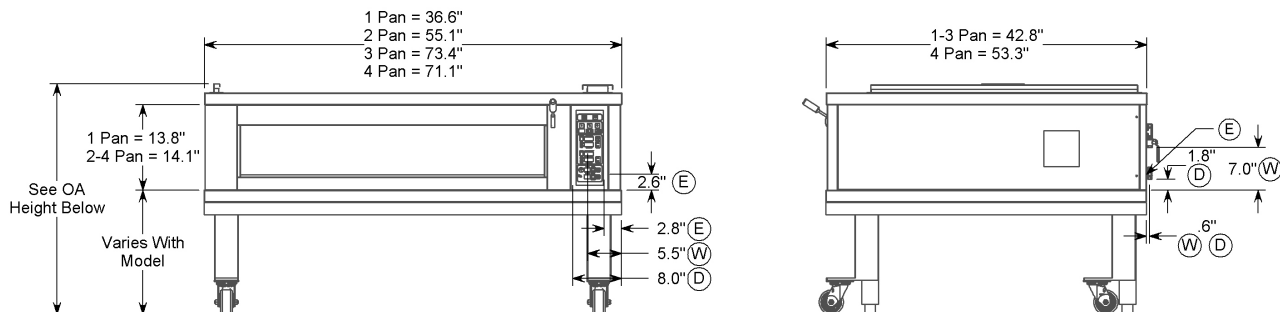

Water Quality Requirements:

pH: 7.0-8.5
Total Hardness < 50 ppm
Chlorides < 50 ppm
Total Chlorine < 0.5 ppm
Iron < 0.3 ppm

Utility Requirements:

Model	Voltage (E)	3 Phase												1 Phase		
		1 Deck			2 Decks			3 Decks			4 Decks			Per Deck		
		kW	MCA	MOP	kW	MCA	MOP	kW	MCA	MOP	kW	MCA	MOP	kW	MCA	MOP
SE-91Y (1 Pan)	208	4.7	20	25	9.4	40	45	14.1	55	70	18.8	75	90	-	-	-
	240	5.9	20	25	11.8	40	50	17.7	60	75	23.6	80	95	5.9	35	40
	480	3.0	15	20	5.9	25	30	8.85	40	45	11.8	50	60	-	-	-
SE-92Y (2 Pan)	208	5.9	25	30	11.8	50	60	17.7	70	85	23.6	95	110	-	-	-
	240	7.5	25	30	15	50	60	22.5	75	90	30	100	120	7.5	40	50
	480	3.8	15	20	7.5	25	30	11.25	40	45	15	50	60	-	-	-
SE-93Y (3 Pan)	208	9.3	40	45	18.6	75	90	27.9	110	140	37.2	150	180	-	-	-
	240	11.7	40	50	23.4	80	95	35.1	120	150	46.8	160	190	11.7	65	75
	480	5.9	20	25	11.7	40	50	17.55	60	75	23.4	80	95	-	-	-
SE-94Y (4 Pan)	208	11.7	45	55	23.4	90	110	35.1	140	165	46.8	180	220	SE-94Y - Not available in single phase		
	240	14.9	50	60	29.8	100	120	44.7	150	180	59.6	200	240			
	480	7.5	25	30	14.9	50	60	22.35	75	90	29.8	100	120			

Shipping Information:

Model	1 Deck		2 Decks		3 Decks		4 Decks		Freight Class
	OA Height	Weight*	OA Height	Weight*	OA Height	Weight*	OA Height	Weight*	
SE-91Y (1 Pan)	52.4 in	445 / 515 lb	66.1 in	790 / 940 lb	72.9 in	1130 / 1405 lb	72.4 in	1475 / 1875 lb	77.5
SE-92Y (2 Pan)		570 / 660 lb		1040 / 1200 lb		1505 / 1745 lb		1975 / 2065 lb	
SE-93Y (3 Pan)	52.7 in	600 / 705 lb	66.8 in	1115 / 1290 lb	73.9 in	1630 / 1890 lb	73.8 in	2145 / 2485 lb	
SE-94Y (4 Pan)		755 / 875 lb		1460 / 1690 lb		2165 / 2505 lb		2870 / 3420 lb	

* Equipment Weight / Shipping Weight