

LBC Electric Rotisserie with Wash System

Model LCR7W



LCR7W Rotisserie
(shown with optional LST7 Stand)

Short Bid Specification:

Rotisserie shall be an **LBC model LCR7W** electrically heated oven with a digital control and integrated wash system. Control shall be capable of storing up to 3 recipes and have large LED displays for Set Point, Actual Temp and Time. Control shall also have 3 step cooking capability with steps for Sear, Roast and Warm/Hold. A momentary jog pushbutton shall be located for elbow-actuation to manually rotate and stop the carousel. A cook/wash selector handle shall activate the automatic wash system. The wash system shall have an internal grease separator with individual drain lines for grease and water. Double-pane loading door shall have tempered full view glass with a hinged inner pane for easy cleaning. Complete rotisserie shall also include all standard features listed and options checked.

Standard Product Warranty:

1 Year Parts and Labor (Contiguous US, Alaska, Hawaii & Canada)

Construction Features:

- Stainless steel interior and exterior
- Full view double pane loading door with low-E reflective coating on panes and hinged inner pane for easy cleaning
- Bright interior lighting
- Conveniently located jog button to safely rotate the carousel for loading and unloading cooked product
- Grease separation system with individual drain lines for wash water and grease

Performance Features:

- Chicken Capacity: 28 - 35
- Fast acting heater elements
- Top mounted fans to thoroughly circulate convection air
- Even browning on all sides of cooked product

Control Features:

- Temperature Range: 145 - 480 deg F
- Large displays for Set Point, Temperature and Time
- Storage capacity for 3 recipes
- 3-step cooking capability
- Buzzer alert when oven has reached temp and when cook is complete
- Temperature displays in deg F or deg C
- 9 hour 59 minute timer
- Dedicated Wash button to select "normal" or "heavy" wash cycle

Options and Accessories:

- 208V 3ph 60Hz (standard) or optional 208V 1ph, 240V 1ph or 240V 3ph
- Optional angle spits, fork spits or baskets in stainless steel (standard material)
- 7" legs (standard) or optional LST7 stand with swivel casters
- Loading door frontside only (standard) or doors front and back
- Accessory: Chain restraint kit



Meets UL197 and NSF4 Standards

Sheet Number LCR7W E (Rev P - 5/18)

Installation Requirement:

Each unit ships separately. Placing on stand required.

Options and Accessories (Check as Required):

- 208V 1ph 60Hz
- 240V 1ph 60Hz
- 240V 3ph 60Hz
- SS Angle Spits (standard material)
- SS Fork Spits (standard material)
- SS Baskets (standard material)
- LST7 Stand with Casters
- Chain Restraint Kit

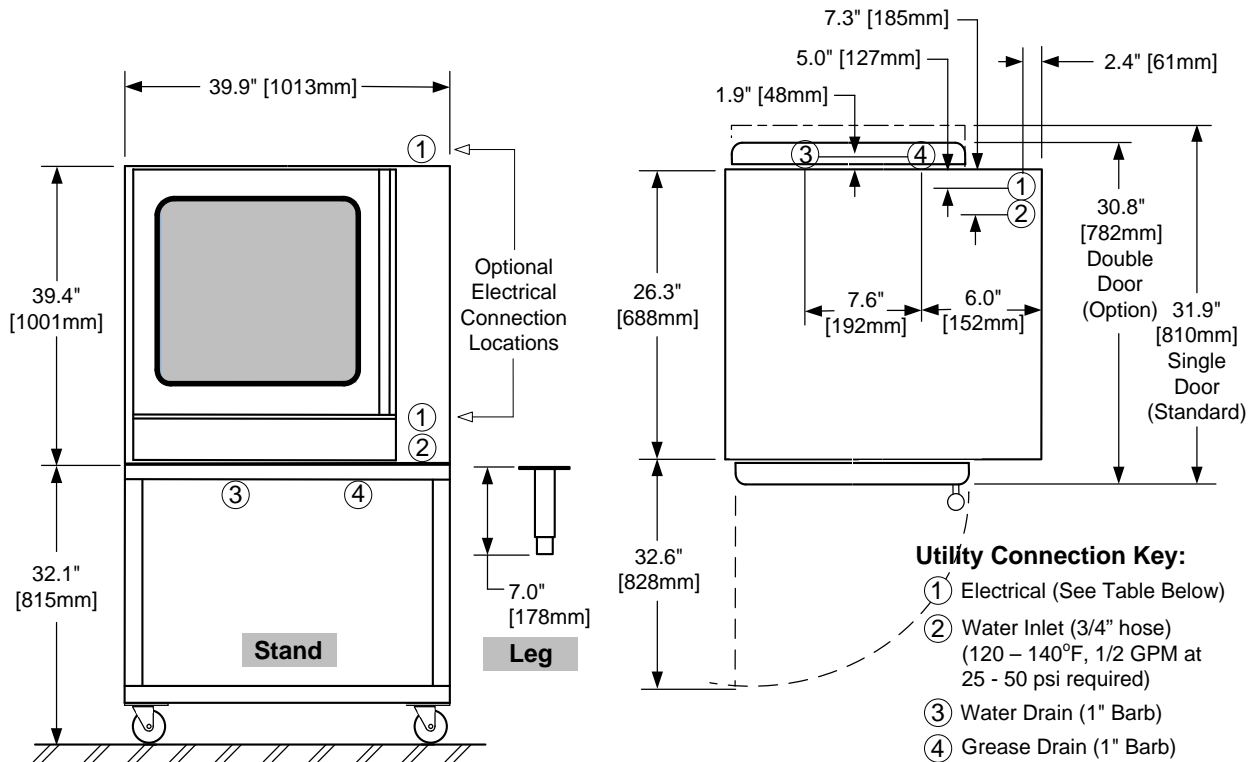

Voltage	kW	MCA		MOP		Shipping Weight	Freight Class
		1 Phase	3 Phase	1 Phase	3 Phase		
208 VAC	8.0	55	N/A	60	N/A	660 lbs [299kg]	85
240 VAC	8.0	50	N/A	60	N/A		
208 VAC	9.0	N/A	40	N/A	60		
240 VAC	9.0	N/A	35	N/A	60		