



Item No. _____
 Project _____
 Quantity _____

BakerSeries [Two Door] Proofer Base

MODEL: LMO-P



MODEL LMP-P Shown

MODEL / PAN CAPACITY

Model	18 x 26 pans
LMO-P	12

Short Bid Specification:

Proofer shall be an **LBC Bakery Equipment Model LMO-P**, 0.9 kW electrically heated, double door proofer base with 4" swivel casters, front casters are locking, Intended for use with the LMO Mini Rack Oven quick responding air-wash heat / humidity system; foam insulated doors and walls; all stainless steel interior and exterior, with 12 pan rack slides; heavy-duty door with magnetic seals and closure system; simple computerized controls, door mounted, with accurate digital temperature, humidity and time readouts; plus all the features listed and options checked.

STANDARD PRODUCT WARRANTY

One-Year Parts and Labor (contiguous US Including Alaska and Hawaii, Canada)

Construction Features

- . Heavy duty stainless steel interior and exterior
- . Walls and doors are foam insulated
- . Rapid responding air-wash heat and humidity system
- . 120 VAC single phase NEMA 5-15 cord and plug
- . 4" Swivel casters, front casters locking

Performance Features

- . PID Controlled heat and humidity system
- . 70 - 120 Degree F proofing range
- . 50 - 99% humidity range
- . Non-submerged calrod type heaters

Controls Features

- . All digital controls mounted in the right door
- . PID Type controls for rapid accurate response without overshoot
- . Digital set temperature, humidity, time
- . Installed in the right hand door
- . Large LED displays



Sheet Number LMO-P v 1 (rev 04/09)

BakerSeries [Two Door] Proofer Base

MODEL: LMO-P

INSTALLATION REQUIREMENT

120 VAC Single phase 15 AMP dedicated circuit
 6'-00" Corde and NEMA 5-15 plug included

3/8" Flexible cold water connection
 3/4" NPT vented drain connection

OPTIONS & ACCESSORIES

60" Water connection kit (3/8" NPT Flex Line) NSF
 120" Flexible drain line kit (w/clamp) USDA

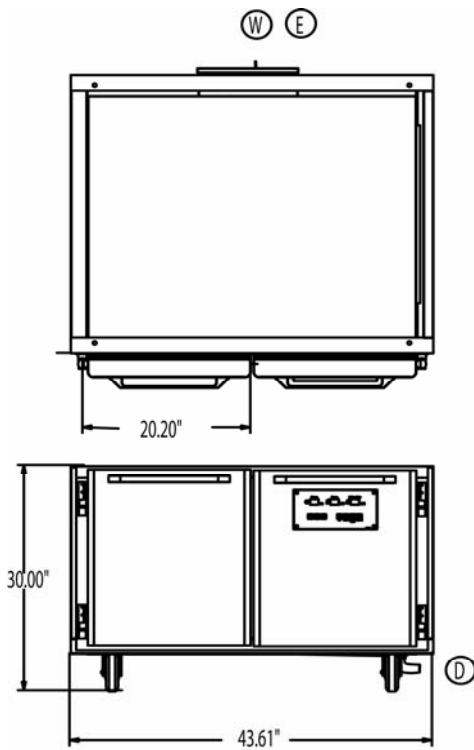

- Ⓜ 3/8" NPT Flexible Line with Shut-Off
LBC Optional Kit # 74000-51
- ⓔ NEMA 5-15 Plug
With 6'-00" Power Supply Cord
- ⓓ 3/4" NPT Drain Connection
LBC Optional Kit# 72610-55

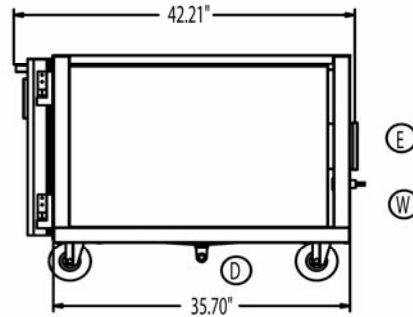

IMPORTANT: Your local water conditions may damage your LBC appliance. Failure to properly treat water may result in damage and may void your warranty. Ensure that your water supply meets these minimum water quality specification.

Parameter	Unit	Value
Alkalinity	ppm	22
Aluminium	ppb	17
Calsium	ppm	3.3
Free Chlorine Residual	ppm	0.6

Parameter	Unit	Value
Magnesium	ppm	0.65
pH	s.u.	8.5
Sodium	ppm	8.5
Total Hardness	ppm	11.9