



**BakerSeries Hydraulic Dough Divider**

Item No. \_\_\_\_\_  
 Project \_\_\_\_\_  
 Quantity \_\_\_\_\_

**MODEL: HDD - Series**



Model HDD-20 shown

**Construction Features**

- Heavy duty stainless steel case
- Teflon coated head for easy release
- Stainless steel knives
- Mounted on front locking casters
- 208/240 VAC 3-phase power input.
- 0" clearance sides and back, 36" at top for operations
- 6' power cord with NEMA L15-20 twist lock plug
- Cast aluminum cover with lock handle
- Spring loaded lid stays in up position when open.

**Performance Features**

- 2 HP Motor
- Push-button "ON" and "Emergency" stop
- Lighted "ON" button
- Single press and divide lever
- Safety lid release (will not open under pressure)

**PAN & PRODUCTION CAPACITY GUIDE**

Capacity / Model	HDD-16		HDD-20	
Dough Lbs.	35		35	
No. Divisions	16		20	
Piece / Size	4.5	35 Oz	3.5	28 Oz

**Short Bid Specification:**

Dough Divider shall be a **LBC Bakery Equipment Model HDD** \_\_\_\_\_  
 [Insert: 16, 20] 208 / 240 volt 3-phase 8 amp, 35 - pound dough capacity, equipped with stainless steel cutting knives, Teflon coated head, supplied with 6' power cord with NEMA L15-20 twist lock plug. Divider shall be equipped with a safety lid lock lever that shall not allow the lid to open when contents are under pressure. Divider shall have teflon coating on the pressure head plates to allow easy release of dough products without the use of oils or flour. Units shall be mounted on two locking swivel casters and two non-locking swivel casters.

**STANDARD PRODUCT WARRANTY**

One-Year Parts and 90 days Labor (contiguous US Including Alaska and Hawaii, Canada)



Sheet Number EDO-RR1 (rev 06/06)



**BakerSeries Hydraulic Dough Divider**

**MODEL: HDD - Series**

**INSTALLATION REQUIREMENT**

208 or 240 VAC, 3-Phase, 15 amp circuit, NEMA L15-20 Receptacle (motor direction sensitive)

**OPTIONS & ACCESSORIES**

Supplied with 6' Type SO cord and plug

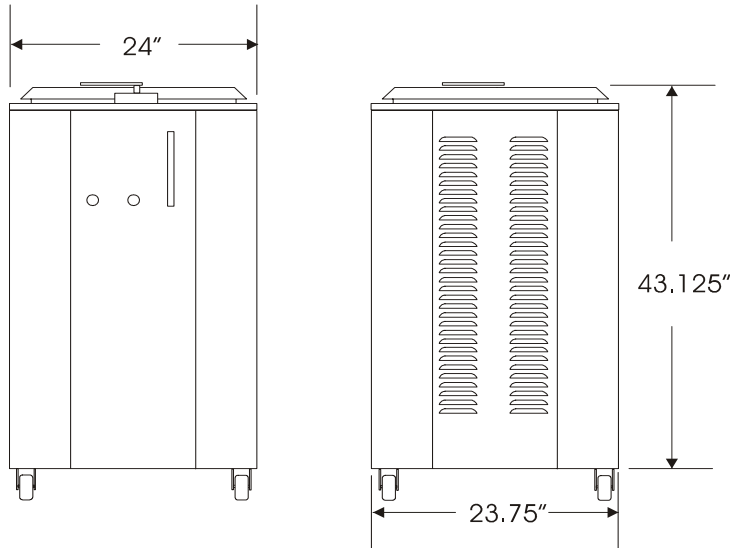

Model	Dimensions Height x Width x Depth External	Clearance from Combustibles		Weight Shipping	Freight Class
		Sides and Back	Top		
HDD-16	43.125" x 27.50" x 26.75"	0"	36"	980	85
HDD-20		0"	36"	980	85

Electrical Specifications By Model							
Voltage	Phase	HDD-16			HDD-20		
		Hp	Amps	Plug	Hp	Amps	Plug
208 VAC 60Hz	3	2	8	L15-20	2	8	L15-20
240 VAC 60Hz	3	2	8	L15-20	2	8	L15-20

\* Note: Dividers are motor direction sensitive. Supply must be properly phased.